



»» CSM 60-100
DRD 60-100

»» DRD 60-100 PM

Oil-injected screw
compressors
Fixed and variable speed



HIGH PERFORMANCE COMPONENTS MAKE FOR CSM 60-100 AND DRD 60-100 SERIES



Reliability

- » Designed with 75 years industry experience
- » Careful qualification of components
- » Continuous endurance testing
- » World class branded electricals

Safety

- » Emergency stop
- » Protection grid
- » Internal and external protection for the electric fan

Quality assurance

- » High capacity oil/air coolers, perfect air filtration and cooling guarantee less thermal shocks and a longer life
- » ISO9001, ISO14001 quality assurance
- » OHSAS 18001 quality assurance
- » End to end quality testing procedure

Easy installation and service

- » Plug and play design
- » No special foundation needed
- » Easy access to all service components
- » Minimum downtime at service intervention



1



Air cooler & oil cooler

Separate oil and air cooler for high-quality cooling. Perfect work at 46° C ambient temperature

2



ES400T controller

Easy-to-use, graphical touchscreen display with integrated connectivity to optimize and save energy.

3

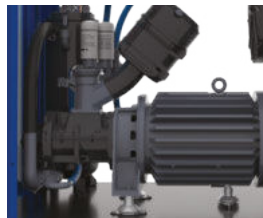

Ceccato's in-house designed element

Guarantee the quality of compressed air and efficient operation

4



High efficiency air filter

Low pressure drop, less noise and 99.9% removal efficiency at 3µm solid particles

5



Integrated fan

Start/stop coordinated by controller in accordance with the oil temperature

PRODUCT FEATURES AND OPTIONS



Technical data

Model									
	Pressure	Motor		Capacity		Noise	Weight	Connection	Dimension
	Mpa	kw	hp	I/S	cfm	dB(A)±2	KG	G	LxHxW(mm)
CSM60	0.8	45	60	127	269	72	866	G1 1/2	1723*980*1600
CSM60	1	45	60	118	250	72	866	G1 1/2	1723*980*1600
CSM60	1.3	45	60	101	213	72	866	G1 1/2	1723*980*1600
CSM75	0.8	55	75	155	328	76	1221	G2	1950*1090*1600
CSM75	1	55	75	144	305	76	1222	G2	1950*1090*1600
CSM75	1.3	55	75	124	263	76	1223	G2	1950*1090*1600
CSM100	0.8	75	100	206	437	77	1285	G2	1950*1090*1600
CSM100	1	75	100	186	393	77	1285	G2	1950*1090*1600
CSM100	1.3	75	100	163	346	77	1285	G2	1950*1090*1600

Model									
	Pressure	Motor		Capacity		Noise	Weight	Connection	Dimension
	Mpa	kw	hp	I/S	cfm	dB(A)±2	KG	G	LxHxW(mm)
DRD60	0.8	45	60	133	281	70	906	G1 1/2	1723*980*1600
DRD60	1	45	60	114	241	70	906	G1 1/2	1723*980*1600
DRD60	1.3	45	60	100	211	70	906	G1 1/2	1723*980*1600
DRD75	0.8	55	75	170	359	74	1461	G2	2259*1060*1594
DRD75	1	55	75	146	310	74	1462	G2	2259*1060*1594
DRD75	1.3	55	75	125	266	74	1463	G2	2259*1060*1594
DRD100	0.8	75	100	230	487	75	1535	G2	2259*1060*1594
DRD100	1	75	100	205	433	75	1535	G2	2259*1060*1594
DRD100	1.3	75	100	172	364	75	1535	G2	2259*1060*1594

Pioneering components make for a revolutionary range

- 1 Filtration panel
- 2 Controller
- 3 Oil filter
- 4 Air filter
- 5 Air cooler & oil cooler
- 6 Oil-separator vessel
- 7 Screw element

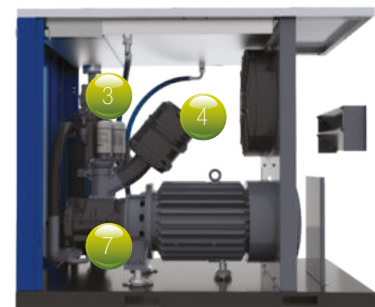
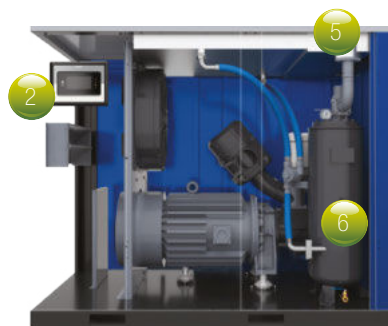

VARIABLE SPEED SERIES: DRD 60-100 PM

Concerning to the factory life-cycle cost, the minimal operation cost can really benefit customer investment. Designed for frequently commissioning at load and unload condition, Ceccato DRD PM permanent magnet drive air compressor meets the minimum power consumption to throughout the long-term commissioning and it can cut your energy bill by up to 30%. DRD PM offer you:



ES4000T controller

- Remotely connect to your compressor anywhere, at any given moment
- Maximize productivity by eliminating the risk of downtime
- Increase reliability through planned service interventions
- Reports suggest cost optimizations

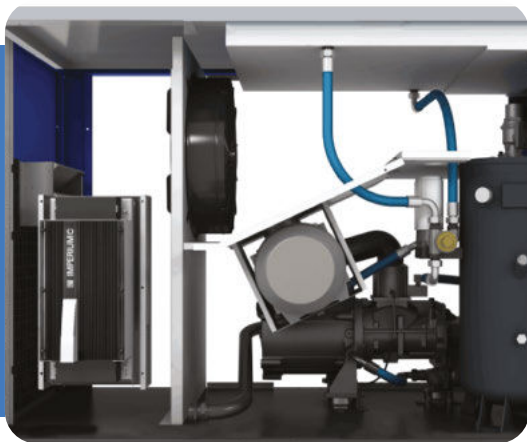

Imperium inverter

In-house designed Imperium inverter ensures perfect match between air demand and air supply.

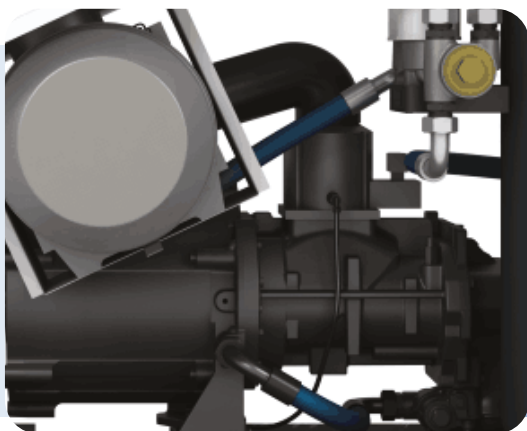

Drive train

Reliable and high efficiency drive train: unique design, lower fabrication to reduce energy loss and optimize operation cost

RELIABLE AND HIGH EFFICIENCY DRIVE TRAIN: UNIQUE DESIGN, LOWER FABRICATION TO REDUCE ENERGY LOSS AND OPTIMIZE OPERATION COST



Model									
	Pressure	Motor		Capacity		Noise	Weight	Connection	Dimension
	Mpa	kw	hp	I/S	CFM	dB(A)±2	KG	G	LxHxW(mm)
DRD60 PM	0.8	45	55	26-134	56-286	71	733	G1-1/2	1723*980*1600
	1	45	55	26-125	56-265	71	733	G1-1/2	1723*980*1600
	1.3	45	55	41-101	88-215	71	733	G1-1/2	1723*980*1600
DRD75 PM	0.8	55	75	27-182	56-385	72	932	G2	2210*1060*1600
	1	55	75	27-164	56-346	72	932	G2	2210*1060*1600
	1.3	55	75	44-139	92-293	72	932	G2	2210*1060*1600
DRD100 PM	0.8	75	100	28-213	60-452	77	973	G2	2210*1060*1600
	1	75	100	28-187	60-395	77	973	G2	2210*1060*1600
	1.3	75	100	43-165	92-349	77	973	G2	2210*1060*1600

Features and benefits

- 1 Maintenance-free components
- 2 Less downtime
- 3 Robust and user-friendly
- 4 Industrial leading efficiency class



REVOLUTIONARY DRIVE TRAIN TECHNOLOGY

Improved energy efficiency saves you money

- » In-house designed iPM motor with iPM Super Premium Efficiency.
- » New generation in-house designed screw elements, with improved efficiency.
- » Integrated direct drive transmission for minimal losses.
- » Smart inlet valve optimizes the inlet flow and improves efficiency.

Increased reliability extends lifetime

- » iPM motor rated IP66, premium protection against dust and water ingress.
- » Globally renowned screw elements, proven in thousands of installations.
- » Optimal cooling at all speeds and conditions thanks to oil-cooling principle of the iPM motor.

Maintenance-free design minimizes downtime and improves your productivity

- » Coupling-free direct drive design, no maintenance needed.
- » Smart inlet valve, no maintenance needed.

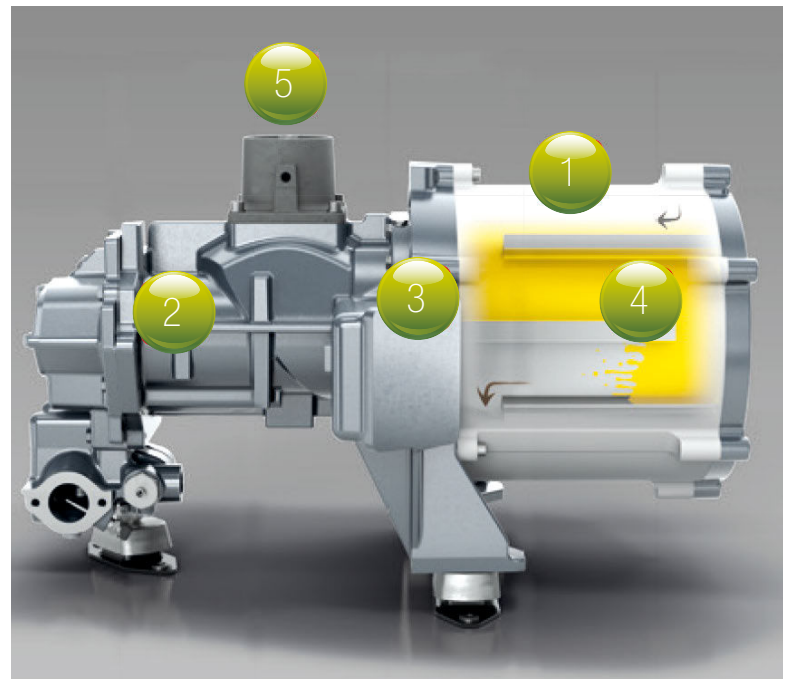

- 1 iPM motor
- 2 In-house designed screw elements
- 3 Direct drive
- 4 Oil-cooling
- 5 Smart inlet value

»»» We protect your efficiency

Energy costs represent about 70% of the total operating cost of your compressor over a 5 year period. That's why reducing the operating cost of a compressed air solution is a major focus. Variable frequency driven compressors can cut the energy bill of your compressor by up to 30%.

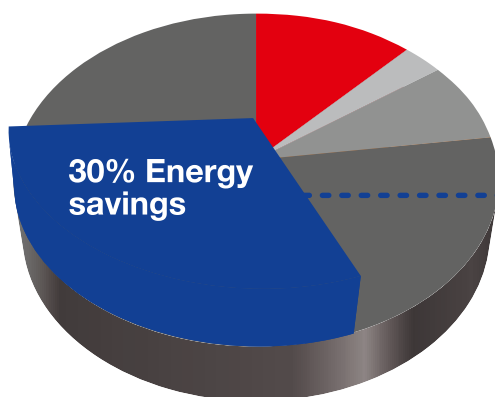

- 12% investment
- 3% installation
- 8% Service
- 77% Energy consumption

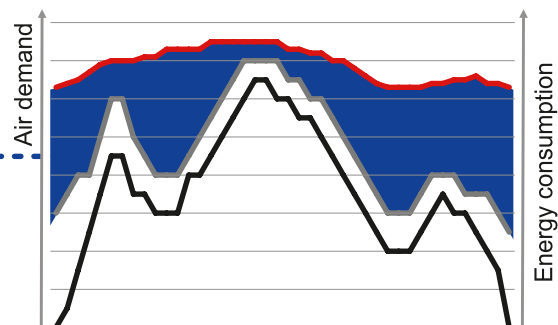

- Air demand
- Variable frequency driven costs
- Load Unload costs
- Savings

A TOTAL SOLUTION FOR YOUR QUALITY AIR

Complete compressor room solutions



Line Filters

- » Purify the compressed air by eliminating oil/dust contaminants resulting in higher final product quality and an increase of your overall productivity.

Air Receiver

- » Buffer storage for compressed air. Helps with condensate separation, pressure stabilization and more efficient operation of the compressor.

Oil Water Separator

- » Captures the oil in compressor condensate so it can be disposed of in a safe and environment-friendly way.

AIRnet

- » Fast to install, reliable piping system, designed for compressed air applications offers lowest total cost of ownership.

Complete your compressed air installation with an ICONS plan

What if your compressor needs service or an immediate intervention? With an ICONS plan, you get an alert from your controller delivered straight to your computer, tablet or smartphone. Wherever you are, you can take immediate action and reduce the risk of downtime and other costs.



With connectivity



Without connectivity





Oil-injected screw compressor

**Fixed speed
Range CSM/DRD series**

**Variable speed
Range DRD PM series**



- A high quality product offering you **technology you can trust**.
- Our products are **easy to use** and guarantee high **reliability**.
- Distributors are always nearby ensuring **availability** of both products and support.
- Choosing our high performance products entails a **partnership** that will boost your business.
- Safeguarding long-term productivity through optimal **serviceability** and use of original parts.



Care. Trust. Efficiency.

Care.

Care is what service is all about: professional service by knowledgeable people, using high-quality original parts.

Trust.

Trust is earned by delivering on our promises of reliable, uninterrupted performance and long equipment lifetime.

Efficiency.

Equipment efficiency is ensured by regular maintenance. Efficiency of the service organization is how Original Parts and Service make the difference.

© 2020, Ceccato. All rights reserved. All mentioned brands, product names, company names, trademarks and service marks are the properties of their respective owners. Our products are constantly being developed and improved. We thus reserve the right to modify product specifications without prior notice. Pictures are not contractually binding.

980113201711



Contact your local sales representative now!

www.ceccato-compressors.com