

MASTERQ
Refrigerant Air Dryers

**Q-DRY11, Q-DRY15, Q-DRY22, Q-DRY32,
Q-DRY45, Q-DRY57, Q-DRY72, Q-DRY84,
Q-DRY107, Q-DRY138, Q-DRY171, Q-DRY200**

Instruction booklet

Refrigerant compressed air dryers

Q-DRY11, Q-DRY15, Q-DRY22, Q-DRY32,
Q-DRY45, Q-DRY57, Q-DRY72, Q-DRY84,
Q-DRY107, Q-DRY138, Q-DRY171, Q-DRY200

Instruction booklet

Original instructions

Copyright notice

Any unauthorised use or copying of the contents or any part thereof is prohibited.

This applies in particular to trademarks, model denominations, part numbers and drawings.

NO. 1639 6909 96/2018-03 Printed

CONTENTS

1	GENERAL SAFETY STANDARD	1
1.1	DESCRIPTION OF DANGER SIGNALS	1
2	GENERAL DESCRIPTION	2
2.1	GENERAL VIEW	2
2.2	AIR SYSTEM	4
2.3	REFRIGERATION SYSTEM	5
2.4	AUTOMATIC REGULATION SYSTEM	6
2.5	CONDENSATE DRAIN SYSTEM	7
3	INSTALLATION	9
3.1	DRYER ROOM	9
3.2	EXAMPLES OF INSTALLATION	10
4	OPERATING INSTRUCTIONS	11
4.1	WARNING	12
4.2	CONTROL PANEL	12
4.3	PDP CONTROLLER	13
4.4	STARTING	15
4.5	DURING OPERATION	15
4.6	STOPPING	16
5	DIMENSIONS AND TECHNICAL DATA	17
5.1	CONNECTIONS	17
5.2	DIMENSIONS	18
5.3	TECHNICAL DATA	18
5.4	REFERENCE CONDITIONS	19
5.5	LIMITATIONS	19
6	TRANSPORT AND HANDLING	20
7	ROUTINE MAINTENANCE	21
8	TROUBLESHOOTING	22

ADDRESSES OF ASSISTANCE CENTERS

In the event of breakdown or malfunction of the machine, switch it off and do not tamper with it.

If repairs are needed, contact a technical assistance center approved by the manufacturer and insist on the use of original spare parts.

Failure to comply with the above may endanger the safety of the machine.

Keep this manual with care for future consultation; the use and maintenance manual is an integral part of the machine.

Read this manual carefully before carrying out any operations on the compressor unit. The installation of the compressor unit and all operations involving it must be performed in conformity with the regulations in force concerning electric plants and personal safety.

1 GENERAL SAFETY STANDARD



BEFORE REMOVING THE PROTECTION DEVICES FOR ANY MAINTENANCE WORK ON THE MACHINE, DISCONNECT THE ELECTRICAL POWER SUPPLY. MAKE SURE THAT THERE IS NO INTERNAL RESIDUAL PRESSURE.

ALL WORK ON THIS MACHINE MUST BE CARRIED OUT BY AUTHORISED & PROFESSIONALLY SKILLED PERSONNEL.

Note: Any tampering with the machine or alterations not approved beforehand by the manufacturer relieve the latter of responsibility for any damage resulting from the above actions.

1.1 DESCRIPTION OF DANGER SIGNALS

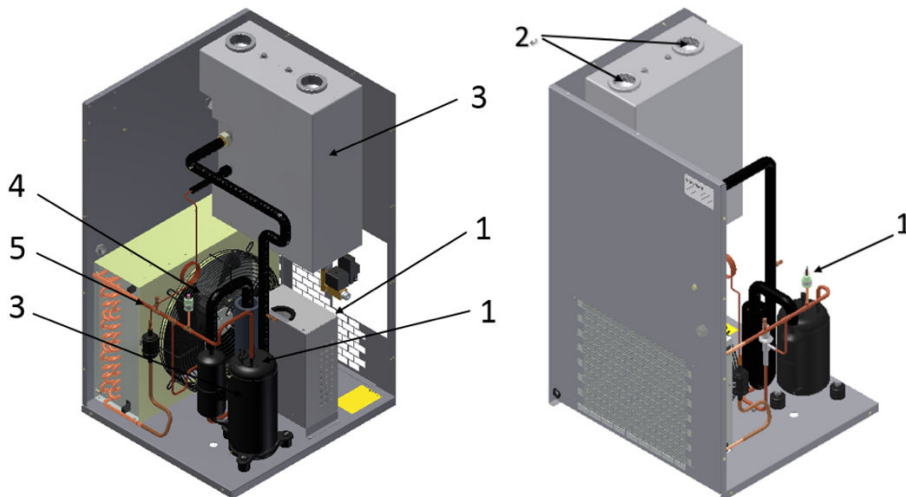

2 GENERAL DESCRIPTION

2.1 GENERAL VIEW

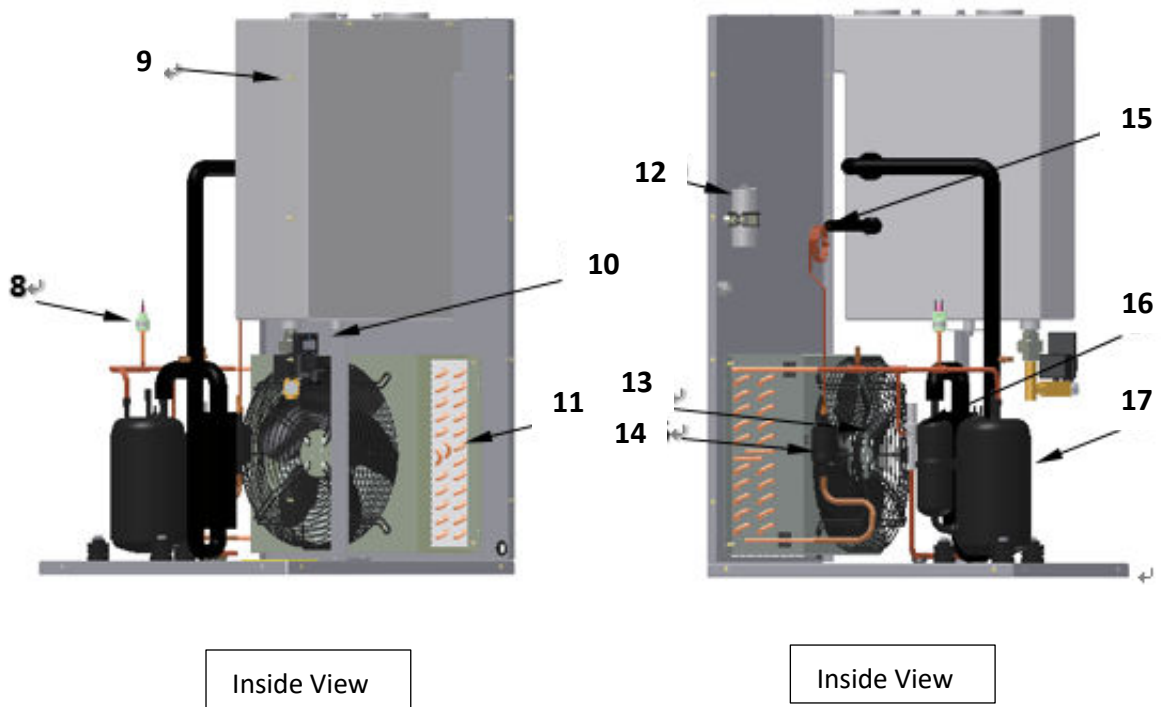
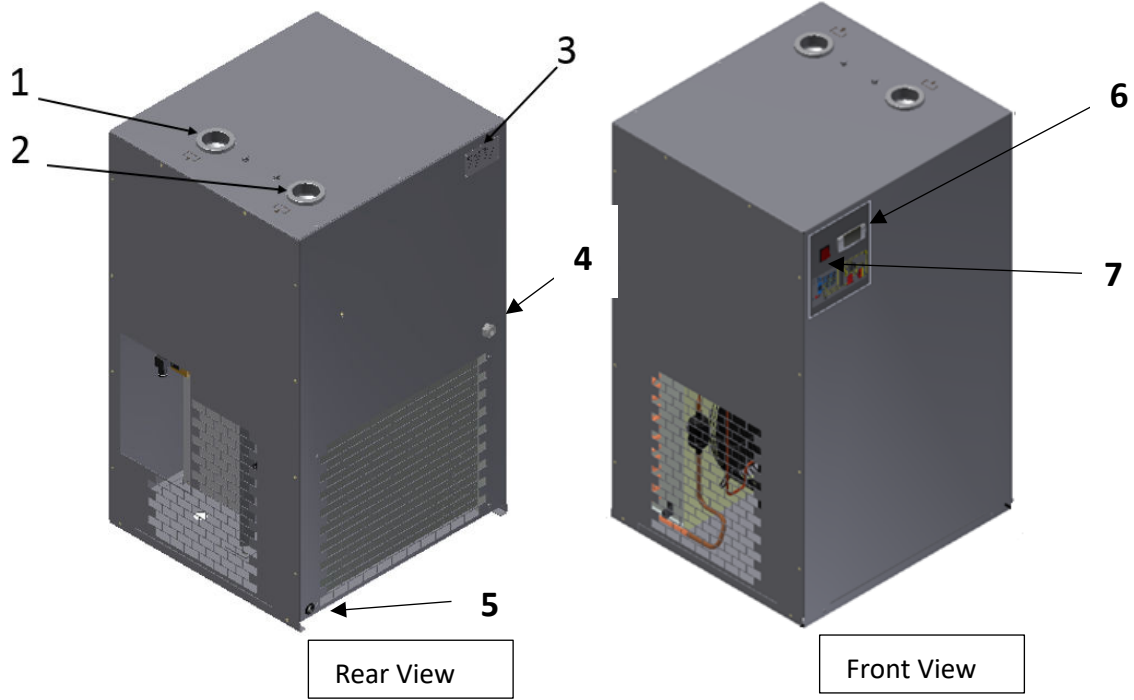

Reference	Name
1	Air outlet
2	Air Inlet
3	Data plate
4	Electrical cable outlet
5	Condensate drain outlet
6	Dew point indicator
7	Dryer on/off switch
8	High pressure switch
9	Heat exchanger
10	Electrical timer drain
11	Condenser
12	Capacity
13	Motor fan
14	Refrigerant filter
15	Capillary
16	Hot gas by-pass valve
17	Refrigerant compressor

Introduction

The dryer is a chilling machine with direct expansion and dry evaporator. The air to be dried is sent to the heat exchanger in which the water vapor present is condensed: the condensate gathers in the separator and is discharged outside through a steam trap.

2.2 AIR SYSTEM

Air flow diagram

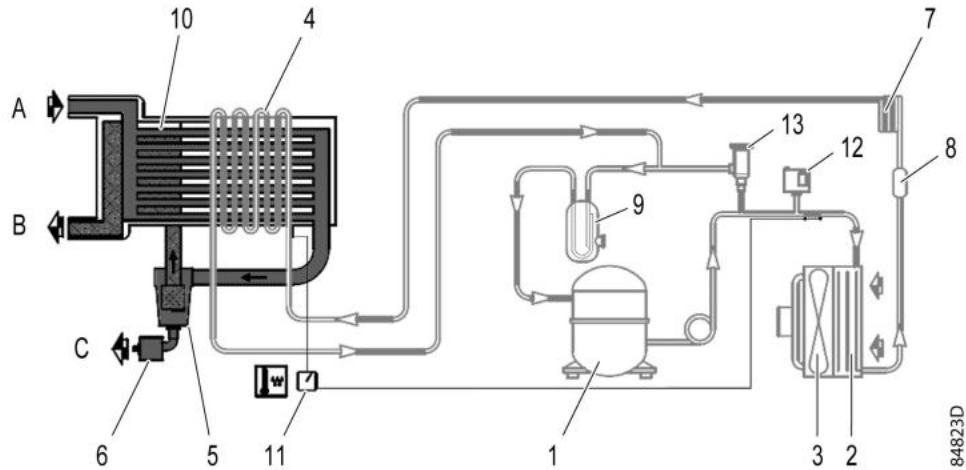

Reference	Name
4	Evaporator
5	Condensate separator
6	Condensate drain
10	Heat exchanger
11	Dew point indicator

Description

Compressed air enters heat exchanger (10) and is cooled by the outgoing, cold, dried air. Water in the incoming air starts to condense. The air then flows through heat exchanger/evaporator (10 & 4) where the refrigerant evaporates causing the air to be cooled further to close to the evaporating temperature of the refrigerant. More water in the air condenses. The cold air then flows through separator (5) where all the condensate is separated from the air. The condensate is automatically drained in the condensate drain (6). The cold, dried air flows through heat exchanger (10) where it is warmed up by the incoming air to approx. 10°C (18°F) below the incoming air temperature. Condensation in the air net cannot occur unless the air is cooled to below the pressure dew point indicated by the digital dew point indicator (11).

2.3 REFRIGERATION SYSTEM

Refrigerant flow diagram

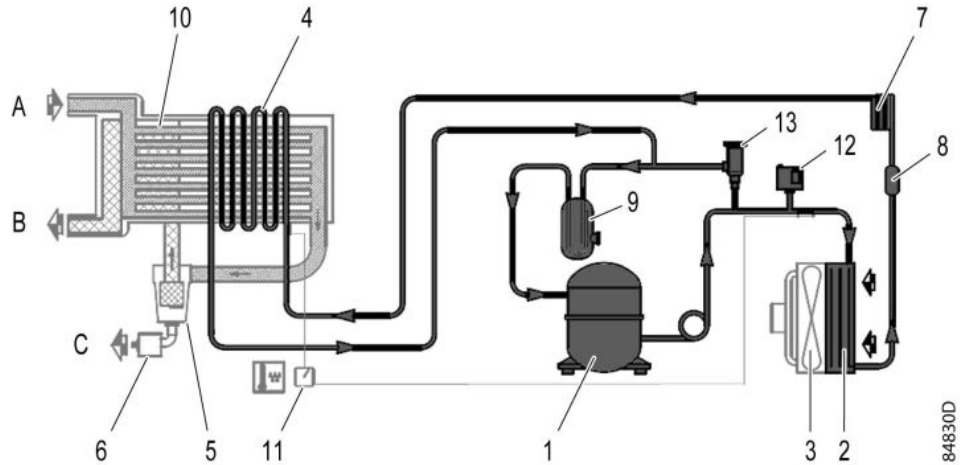

Reference	Name
1	Refrigerant compressor
2	Condenser
4	Evaporator
7	Capillary tube
8	filter
9	Liquid separator
12	High pressure switch
13	Hot gas by-pass valve

Description

Compressor (1) delivers hot, high-pressure refrigerant gas which flows through condenser (2) where most of the refrigerant condenses. The liquid flows through liquid refrigerant dryer/filter (8) to capillary tube (7). The refrigerant leaves the capillary tube at evaporating pressure. The refrigerant enters evaporator (4) where it withdraws heat from the compressed air by further evaporation at constant pressure. The heated refrigerant leaves the evaporator and flows through the liquid separator (9) back to the compressor (1).

2.4 AUTOMATIC REGULATION SYSTEM

Air and refrigerant flow diagram

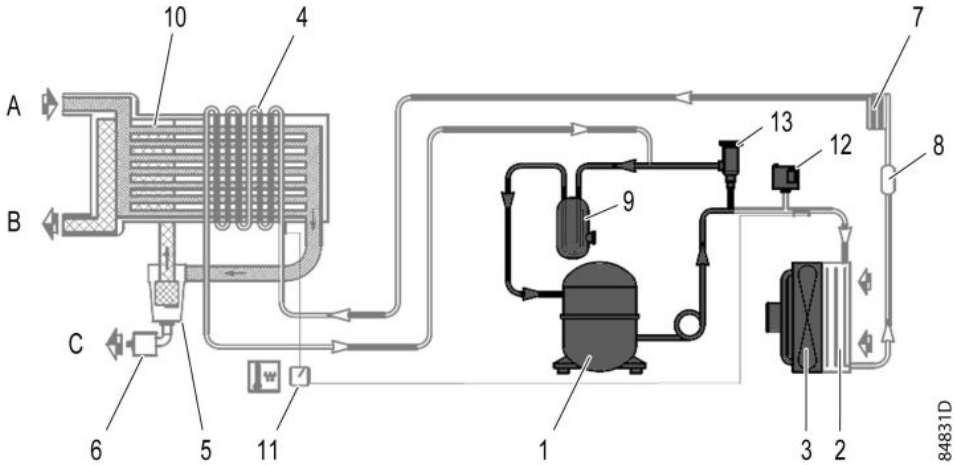

Reference	Name
1	Refrigerant compressor
3	Motor fan
9	Liquid separator
12	High pressure switch
13	Hot gas by-pass valve

Description

The condenser pressure must be kept as constant as possible to obtain stable operation. Fan control switch therefore stops and starts the cooling fan (3). If, under partial or no load, the evaporator pressure drops below a certain level, the hot gas by-pass valve (9) opens and hot, high-pressure gas is fed to the evaporator circuit to prevent the evaporator pressure from dropping any further.

2.5 CONDENSATE DRAIN SYSTEM

Description

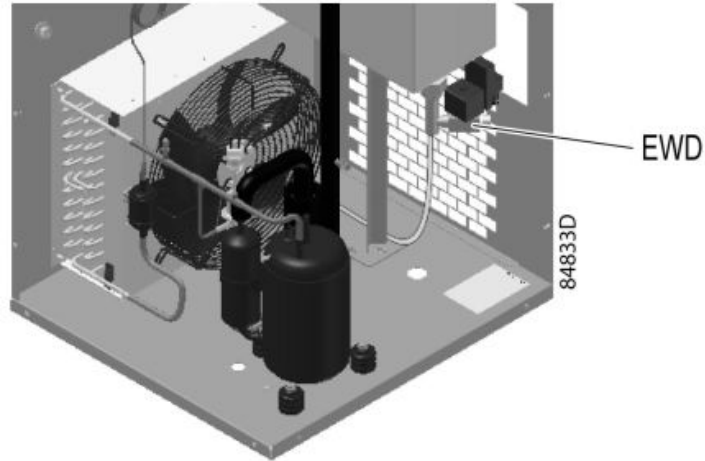

Electronic water drain

The dryers are equipped with an electronic water drain (EWD). The condensate from the condensate trap accumulates in a collector. On preset time intervals, the condensate is discharged through the drain outlet. The opening time is limited to 1 second, which limits compressed air waste to a minimum. The condensate can also be drained by pressing the test button (1).

Control panel

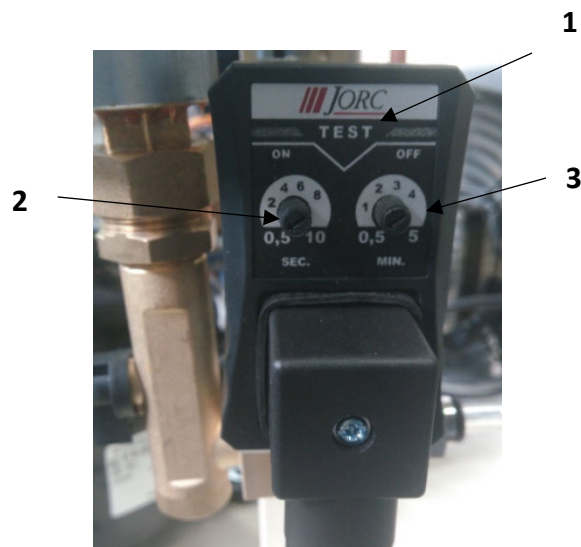

Reference	Description
1	Test
2	On
3	Off

Setting:

1. Switch on the power. Note: the voltage must comply with the voltage mentioned on the coil.
2. It will start with its pre-set time setting of 0.5 min OFF and 1 sec ON time.
3. You can change the pre-set values to anything ranging from 0.5-10 sec and 0.5-5 Min.
4. To change the ON time simply rotate the black knob, the point of the arrow is the drainage time, then the change is saved.
5. To change the OFF time simply rotate the black knob, the point of the arrow is the drainage interval, then the change is saved.

Note:

When the test button is pressed during normal operation, it starts a manual drain test.

3 INSTALLATION

3.1 DRYER ROOM

EXAMPLE OF COMPRESSOR/DRYER ROOM

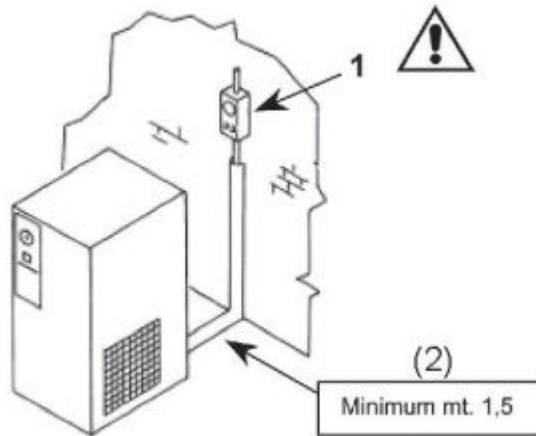

Reference	Description
–	<ul style="list-style-type: none"> The refrigerant dryer should be installed on a level floor suitable for its weight.
–	<ul style="list-style-type: none"> Install the dryer where the ambient air is as clean as possible and where the temperature of the air will never exceed the limits. See Reference conditions and limitations. Keep the ventilation gratings of the dryer free. The recommended minimum distance between the top of the unit and the ceiling is 1.5m (58.5 in). The minimum distance between the wall and the back of the dryer must be 1.5 m (58.5in). Lay out the condensate drain hose via a funnel towards a drain collector to allow visual inspection. The hose must slope downwards. If the condensate drain has been fitted outside the dryer room where it may be exposed to freezing temperatures, it must be insulated.
–	<ul style="list-style-type: none"> The power cable must be connected by a qualified electrician. Connect dryer to the correct voltage; if necessary, check the unit data plate. Check that the electrical installation corresponds to local codes. The dryer must be earthed and protected against short circuits using an automatic cut-out device with a differential device. An isolating switch must be installed near the dryer.
–	<ul style="list-style-type: none"> Connect the compressed air lines to the marked inlet and outlet pipes of the dryer (see Dimension drawings). Provide an air inlet valve and outlet valve. If a bypass pipe and valve are installed, the dryer can be serviced while it is bypassed.

2.1 EXAMPLES OF INSTALLATION

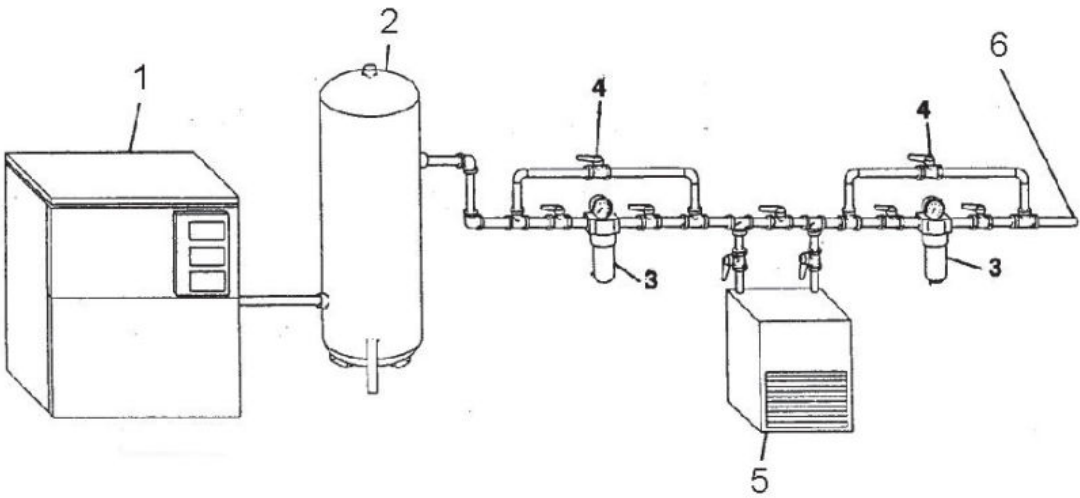

Dryer and filters downstream the air receiver

This can be used when the compressor runs constantly and the cooling capacity of the dryer is equal to the air delivery of the compressor. Under this condition the load of the dryer is constant.

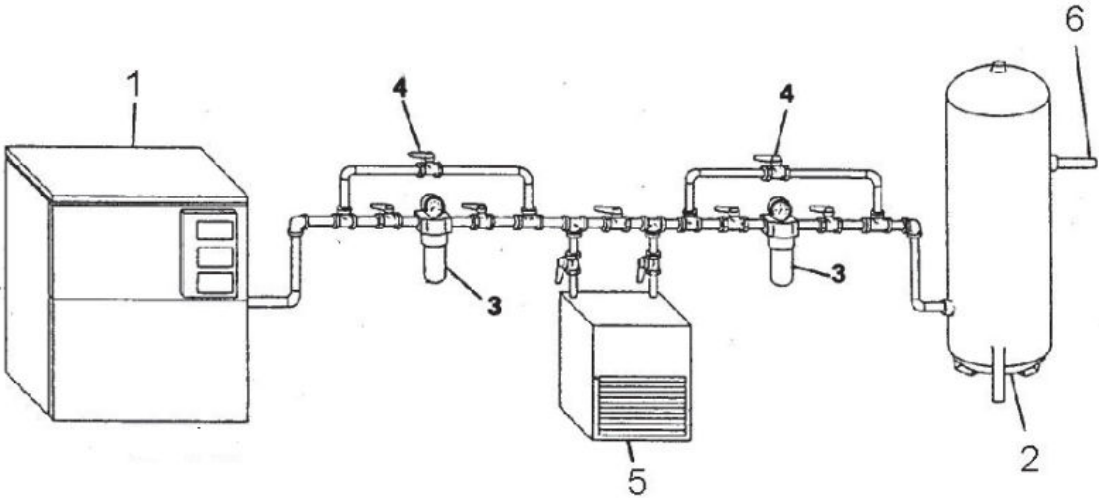

Dryer and filters upstream the air receiver

This can be used when the air demand is variable. The air demand is for short periods higher than the compressor can deliver, the air receiver must be large enough to meet the instant air demand.

Reference	Description
1	Compressor
2	Air receiver
3	Install pre-filters and post-filters
4	Provide an air inlet valve and outlet valve. If a bypass pipe and valve are installed, the dryer and filters can be serviced while by-passing the dryer
5	Dryer
6	Main air line

4 OPERATING INSTRUCTIONS

4.1 WARNING

Safety precautions

The operator must apply all relevant safety precautions, including those mentioned in this manual.

Altitude operation

Consult your supplier if operating above 3,000m (9,843 ft).

4.2 CONTROL PANEL

Description

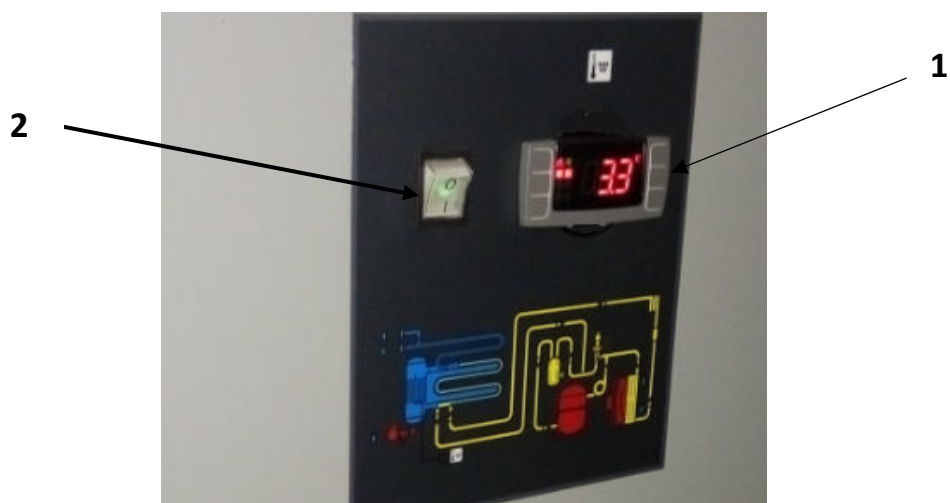

Reference	Description
1	Digital controller, used for: 1. pressure dew point indication (main function) 2. alarms information
2	Dryer On/Off switch



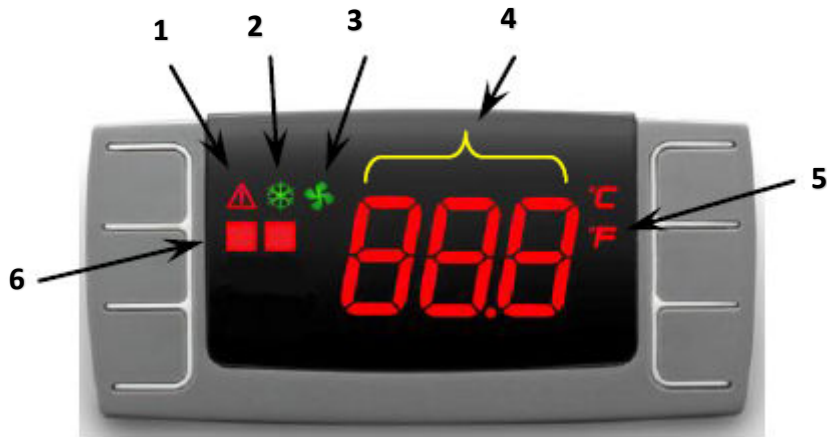



4.3 PDP CONTROLLER



1	Alarm
2	Dryer under tension
3	Fan on
4	PDP value
5	° C or ° F

	ICON	MODE	FUNCTION
	Alarm	OFF	N/A
		ON	Fan probe failed
			High/Low PDP
	Refrigerant compressor	OFF	Dryer stops working
		Flash	Service required
		ON	Dryer working
	Fan	OFF	Fan stops working
		Flash	N/A
		ON	Fan working

Normal operations	Flashing Alarm	Notes	Possible causes	Observations
		Dryer is working OK	n/a	

		Warning icon NOT flashing, label P1 flashing	Fan control probe failed	-Replace probe
		Warning icon NOT flashing, label P2 flashing	PDP Temp probe failed	-Replace probe
		Warning icon NOT flashing, label H2 flashing	High PDP	-Refrigerant leak -Flow rate or temperature exceeding limitations
		Warning icon NOT flashing, label L2 flashing	Low PDP	-Expansion valve out of order -Ambient temperature lower than limits

EE ALARM



EE alarm is shown when internal EPROM errors happens, if this warning appears, the dryer will stop running. The error can be reset by pressing one of the four buttons on the controller, however the controller itself may need replacing.



NOTE: in case of EE alarm please contact your technical support.

LEGEND

ICON	DESCRIPTION	ICON	DESCRIPTION
P1	Probe that controls the fan	P2	Probe that measures the PDP
H2	High PDP	L2	Low PDP
EE	EPROM ERROR	Sn	Software number
rL	Firmware		

4.4 STARTING

Attention

	<p>To ensure optimum operational efficiency, do not use dryer on/off switch repeatedly within a short time period. Wait at least 5 minutes to start the dryer again after stopping to allow pressure equalization.</p>
	<p>To keep the compressed air net free of condensate, start the dryer before starting the compressor and stop the compressor before stopping the dryer.</p>

Procedure

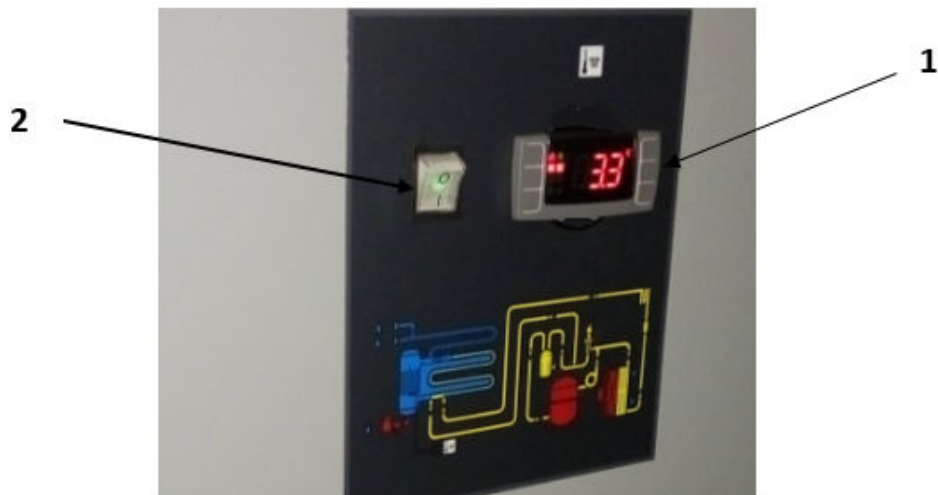

Step	Action
1	If installed, close the dryer by-pass valve. See Installation proposal.
2	Press dryer on/off switch (2).
3	Open dryer air inlet valve (customer's installation).
4	Approx. 5 minutes later, open dryer air outlet valve (customer's installation).
5	Approx. 10 minutes later, the nominal dew point will be reached.



4.5 DURING OPERATION

Regularly check:

- The pressure dew point indicator (1) on the control panel. The pressure dew point will deviate from nominal if the air inlet conditions or volume flow differ from nominal.
- That condensate is discharged via condensate outlet. The amount depends on the operating conditions.

4.6 STOPPING

Attention

	To ensure optimum operational efficiency, do not use dryer on/off switch repeatedly within a short time period. Wait at least 5 minutes to start the dryer again after stopping to allow pressure equalization.
	To keep the compressed air net free of condensate, start the dryer before starting the compressor and stop the compressor before stopping the dryer.

Procedure

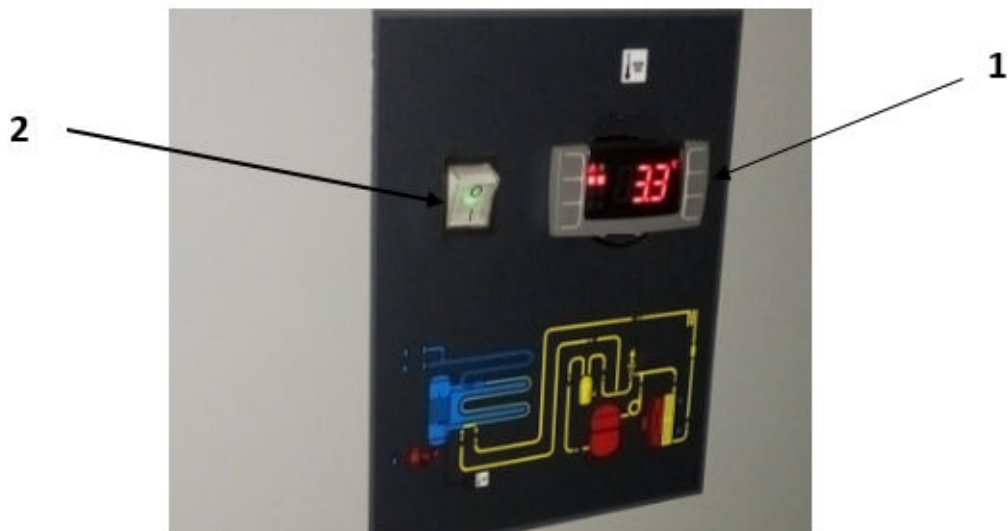

Step	Action
1	Close the dryer inlet and outlet valve (customer's installation).
2	Press dryer on/off switch (2), the dryer stops.
3	If provided, open the dryer by-pass valve.

5 DIMENSIONS AND TECHNICAL DATA

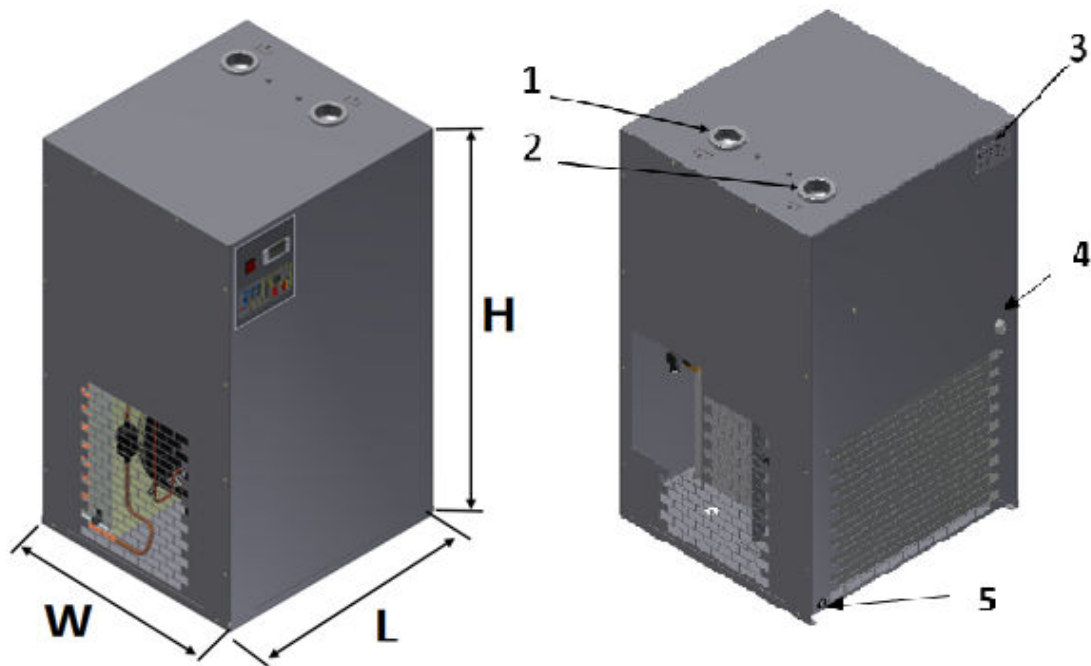

Reference	Name
1	Air outlet
2	Air Inlet
3	Data plate
4	Electrical cable outlet
5	Condensate drain outlet



5.1 CONNECTIONS

TYPE	OUTLET (1)	INTLET (2)	TYPE	OUTLET (1)	INLET (2)
Q-DRY11	G3/4"	G3/4"	Q-DRY72	G2"	G2"
Q-DRY15	G3/4"	G3/4"	Q-DRY84	G2"	G2"
Q-DRY22	G3/4"	G3/4"	Q-DRY107	G2.5"	G2.5"
Q-DRY32	G1"	G1"	Q-DRY138	G2.5"	G2.5"
Q-DRY45	G1.5"	G1.5"	Q-DRY171	G2.5"	G2.5"
Q-DRY57	G1.5"	G1.5"	Q-DRY200	G2.5"	G2.5"

5.2 DIMENSIONS

TYPE	Unit	Length(L)	Width(W)	Height(H)
Q-DRY11	mm	354	430	445
Q-DRY15	mm	550	370	800
Q-DRY22	mm	550	370	800
Q-DRY32	mm	520	500	800
Q-DRY45	mm	550	600	980
Q-DRY57	mm	550	600	980
Q-DRY72	mm	550	600	980
Q-DRY84	mm	900	750	1000
Q-DRY107	mm	1025	660	1120
Q-DRY138	mm	1025	660	1120
Q-DRY171	mm	1025	660	1120
Q-DRY200	mm	1025	660	1120

5.3 TECHNICAL DATA

TYPE	Power	Freon gr.		 + Nominal Power W	 + Max Power W	 Max pressure bar
		R134a	R410A			
Q-DRY11	230	200		222	355	13
Q-DRY15	230	250		360	400	13
Q-DRY22	230	250		364	453	13
Q-DRY32	230		700	951	1170	13
Q-DRY45	230		700	988	1200	13
Q-DRY57	230		900	1000	1312	13
Q-DRY72	230		1000	1125	1443	13
Q-DRY84	230		1400	1674	2143	13
Q-DRY107	230		1600	1700	2240	13
Q-DRY138	230		1700	1990	2740	13
Q-DRY171	230		2000	2220	3190	13
Q-DRY200	230		2300	2610	3760	13

5.4 REFERENCE CONDITIONS

	Unit	
Compressed air inlet pressure	Bar€	7
Compressed air inlet pressure	psig	101.53
Compressed air inlet temperature	°C	40
Compressed air inlet temperature	°F	104
Ambient temperature	°C	30
Ambient temperature	°F	86
Pressure dew point	°C	7
Pressure dew point	°F	44.6

5.5 LIMITATIONS

	Unit	
Maximum compressed air inlet pressure	Bar€	13
Maximum compressed air inlet pressure	psig	188.55
Min.-Max. ambient air temperature	°C	10-45
Min.-Max. ambient air temperature	°F	50-113
Maximum compressed air inlet temperature	°C	55
Maximum compressed air inlet temperature	°F	131

6 TRANSPORT AND HANDLING

- **TRANSPORT**

The machine must be transported as shown in the following figures

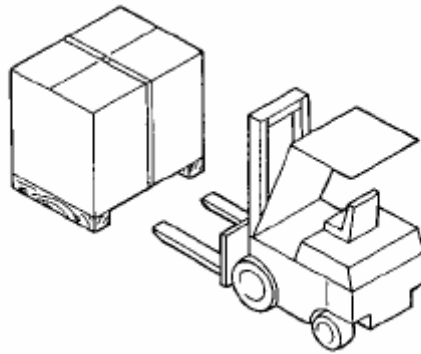

TYPE	NET WEIGHT Kg.	TYPE	NET WEIGHT Kg.
Q-DRY11	30	Q-DRY72	85
Q-DRY15	32	Q-DRY84	120
Q-DRY22	36	Q-DRY107	130
Q-DRY32	60	Q-DRY138	135
Q-DRY45	68	Q-DRY171	150
Q-DRY57	75	Q-DRY200	155

- **UNPACKING**

After removing the packing, ensure that the machine is not damaged and that there are no visibly defective parts. If you are in doubt, do not use the machine – contact distributor.

7 ROUTINE MAINTENANCE



BEFORE CARRYING OUT ANY MAINTENANCE WORKS IT IS OBLIGATORY TO STOP THE MACHINE AND DISCONNECT IT FROM THE POWER MAINS AND FROM THE COMPRESSOR AIR DISTRIBUTION NETWORK.

These maintenance intervals are recommended for work environments that are not dusty and are well ventilated. For particularly dusty environments, double the frequency of controls.

Routine

If you notice any abnormalities during routine maintenance, please stop dryer immediately and do as stated in the “Troubleshooting” section.

Checklist

- No Air or Freon leaks
- No alarm triggered in PDP controller
- Water discharges from condensate drain
- No abnormal noises

Each month

Condenser: Clean the condenser fins to remove dust.

- a. Switch off the machine
- b. Remove the panels
- c. Clean the condenser fins with compressed air. **DO NOT USE WATER OR SOLVENTS**
- d. Close the panels



ALL WORK MUST BE CARRIED OUT BY PROFESSIONALLY SKILLED PERSONNEL. BEFORE CARRYING OUT ANY MAINTENANCE JOBS IT IS OBLIGATORY TO STOP THE MACHINE AND DISCONNECT IT FROM THE POWER MAINS.

8 TROUBLESHOOTING

Attention

	<p>Use only authorised parts. Any damage or malfunction caused by the use of unauthorised parts is not covered by Warranty or Product Liability. Apply all relevant Safety precautions.</p>
	<p>Before carrying out any maintenance or repair work on the dryer: Close air inlet and outlet valve of the dryer. Press the test button on the electronic condensate drain to depressurize the air system. Move dryer on/off switch to position 0. Switch off the voltage. See section Stopping. Open the isolating switch to prevent an accidental start.</p>
	<p>The air inlet and outlet valve can be locked during maintenance or repair work as follows:</p> <ul style="list-style-type: none"> • Close the valve. • Using a wrench, remove the screw fixing the handle. • Lift the handle and turn it until the slot of the handle fits over the blocking edge on the valve body. • Fit the screw.

Faults and remedies

Condition	Fault	Remedy
Pressure dew point too high	Air inlet temperature too high	Check and correct; if necessary, install a pre-cooler.
	Ambient temperature too high	Check and correct; if necessary, draw cooling air via a duct from a cooler place or relocate the dryer.
	Air inlet pressure too low	Increase inlet pressure. Adjust the pressure switch.
	Dryer capacity exceeded	Reduce air flow.
	Shortage of refrigerant	Have circuit checked for leaks and recharged
	The compressor does not run	See 1 & 2 & 3 & 4 & 5

Condition	Fault	Remedy
Condenser pressure too high or too low	Fan or fan motor out of order	Check fan/fan motor
	Ambient temperature too high	Check and correct; if necessary, draw cooling air via a duct from a cooler room or relocate the dryer.
	Condenser externally clogged	Clean condenser.

Condition	Fault	Remedy
Compressor stops or does not start	Electric power supply to compressor is interrupted	Check and correct as necessary.
	Thermal protection of refrigerant compressor motor has tripped	Motor will restart when motor windings have cooled down.
	Restart of the dryer has been too fast, not enough time for pressure balancing	Wait a few minutes and restart.

Condition	Fault	Remedy
Evaporator pressure is too high or too low at unload	Hot gas bypass valve incorrectly set or out of order	Have hot gas bypass valve adjusted
	Condenser pressure too high or too low	Check and correct; if necessary, draw cooling air via a duct from a cooler room or relocate the dryer.
	Shortage of refrigerant	Have circuit checked for leaks and recharged.

Condition	Fault	Remedy
The condensate drain remains inoperative	Drain system clogged	Flush the assembly by opening the manual drain valve. Have system inspected. Clean the inlet filter of the automatic drain by opening by unscrewing the inspection nut. Check function of the drain by pushing the test button.

Condition	Fault	Remedy
Condensate trap continuously discharges air and water	Automatic drain system out of order	Have system checked, if necessary, replace automatic drain.